

# TurboBIST-Memory™

## TOOLS FOR EMBEDDED MEMORIES



SYNTEST

The Testability Company

### BENEFITS

- Automatically generates classical or user configurable test pattern sets
- Includes March C-, Moving Inversion March, March C++ and Checkerboard
- Allows simultaneous, multiple BIST memory test via a shared controller
- Supports embedded SRAMs, ROMs, SDRAMs and CAMs
- Outputs Verilog/VHDL synthesizable RTL code
- Outputs logic synthesis scripts
- Generates Verilog/VHDL test bench code automatically to reduce test design time

### PRODUCT DESCRIPTION

The TurboBIST-Memory family of products from SynTest Technologies, Inc., includes tools for adding highly efficient BIST structures to all types of embedded memories including SRAMs, ROMs, SDRAMs and CAMs. These tools, part of SynTest's complete suite of testability analysis, scan synthesis, ATPG and fault simulation solutions, automatically synthesize the BIST logic surrounding the memory blocks and generate the test patterns needed to provide very high fault coverage testing of complete complex system-on-chip ICs. A single IEEE 1149.1 compliant TAP controller on the chip can be used to control multiple "BISTed" embedded memory cells of all types, as well as for controlling scan and boundary scan functions, thus keeping silicon overhead to the absolute minimum.

### PLATFORMS

TurboBIST-Memory tools run on SUN Solaris, HP-UX and Linux platforms.

### OTHER INFORMATION

SDRAM and CAM BIST are currently available as services from SynTest's Applications Engineering group. SRAM and ROM BIST can be implemented either by using SynTest's services group or by acquiring licenses for the tools for in-house use. Programmable SRAM BIST is also available as a service.

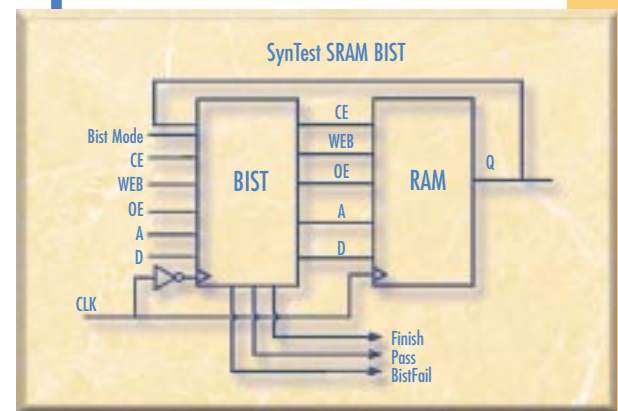
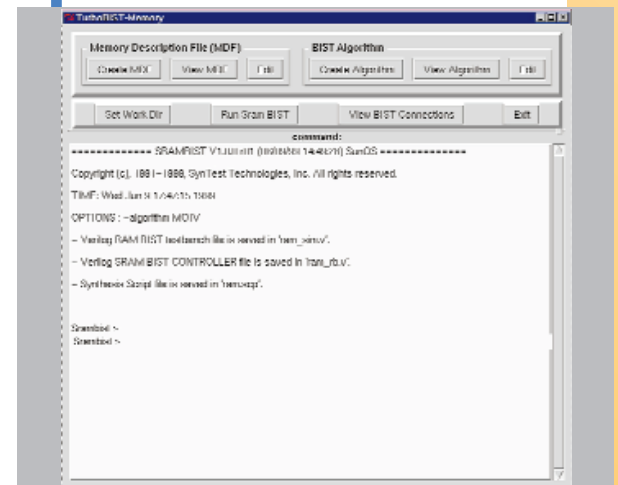
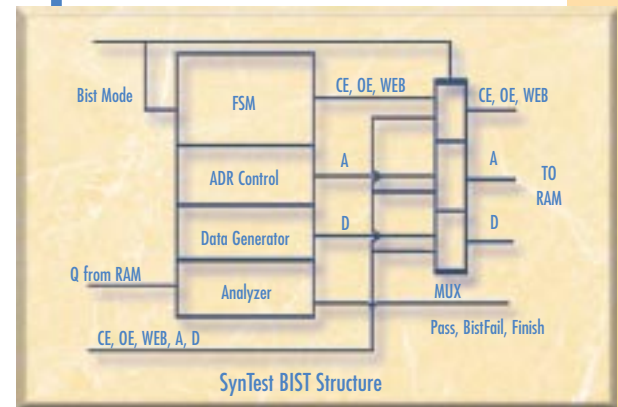

# SynTest Service and Support

## APPLICATIONS ENGINEERING

Part of the mission of the Applications Engineering Group is to help our customers to become their own experts in using our tools. Test synthesis is not a 'push button' process. SynTest tools will make the process much easier. Customers who do not have too much experience in this area can usually use our help to 'kick-start' their projects. The Application Engineering group can provide tools and methodology training at the beginning of the design cycle. During tape-out, we are also available to help with any final critical problems related to test synthesis. Our goal is to have our customers feel that they are not alone after they purchase our tools. We are always there to help.

## CONSULTING ENGINEERING

In addition to direct product sales, part of SynTest's company mission is to emphasize excellent support for our customers. Our Consulting Engineering Group provides test synthesis and ATPG expertise to our customers who may not have enough resources to accomplish these tasks. We provide a wide range of services from design flow methodology integration to a complete turn-key solution for our customers. We have expertise in testability analysis, test synthesis, ATPG, and fault simulation. Our past service projects include Pentium class CPUs, advanced 3D Graphics chips, network communication devices, etc. Please contact SynTest for more information on our Consulting Services.

## THE SYNTTEST PRODUCT FAMILY

The SynTest product family is an ever-growing suite of high quality advanced tools to help you keep pace with the ever-changing requirements for test design, design for test, ATPG, fault simulation and other state-of-the-art testability solutions. If we don't have it today, we'll partner with you to develop it specifically for your needs.

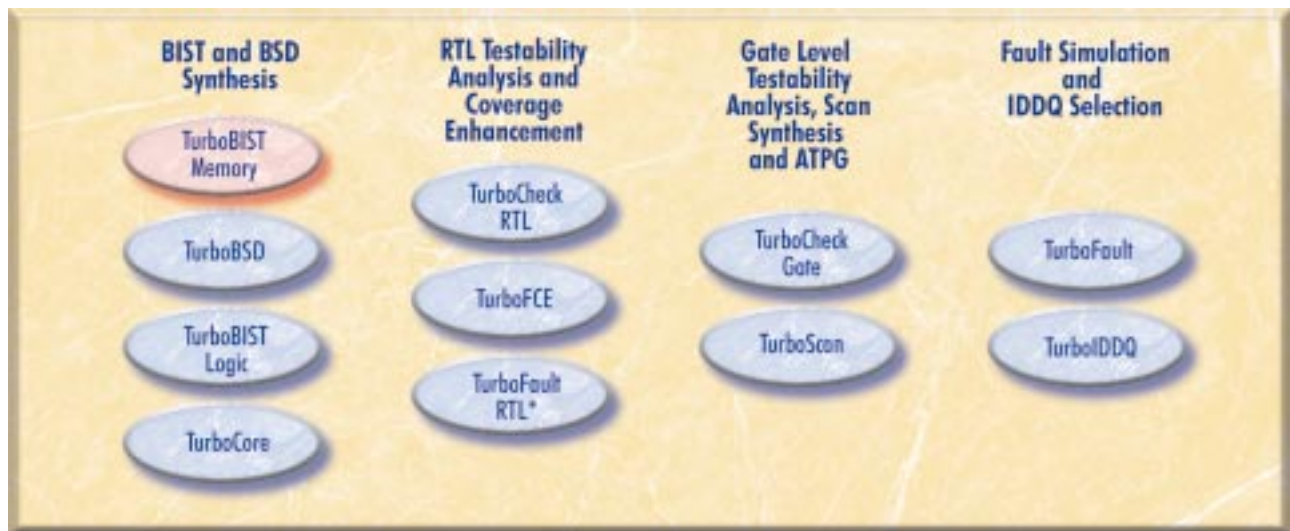

\*Available Mid-1999



**SYNTTEST**

*The Testability Company*

**Offices and Distributors Worldwide** -- Please call, e-mail or visit our web site for the one closest to you. <http://www.syntest.com>

**Corporate Headquarters:**  
SynTest Technologies, Inc.  
505 S. Pastoria Ave., Suite 101  
Sunnyvale, CA 94086

Telephone: 408.720.9956  
Facsimile: 408.720.9960  
E-Mail: [info@syntest.com](mailto:info@syntest.com)